

Year 9 and 10 (English Version)

Thursday, 21st March 2024

Time allowed: 75 minutes

1. For each question exactly one of the 5 options is correct.
2. Each participant is given 30 points at the beginning. For each correct answer 3, 4 or 5 points are added. No answer means 0 points are added. If a wrong answer is given, one quarter of the points is subtracted, i. e. 0.75 points, 1 point or 1.25 points, respectively. At the end, the maximum number of points is 150, the minimum is 0.
3. Calculators and other electronic devices are not allowed.

3 point problems

1. $\frac{20 \times 2.4}{2 \times 0.24} =$

- (A) 0.01 (B) 0.1 (C) 1 (D) 10 (E) 100

2. Which of the following squares is divided into two different parts?

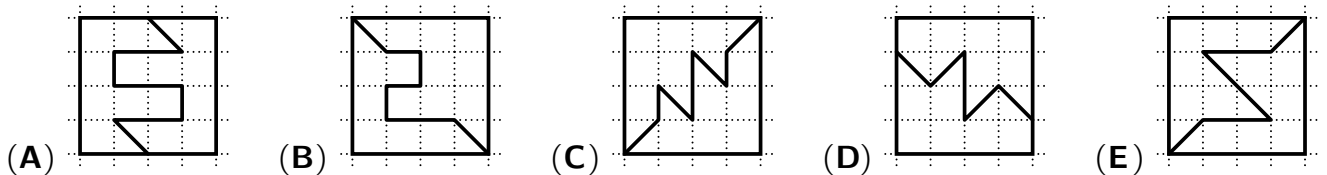

3. Lucas speaks in riddles: "I woke up so early today, it was only halfway through the first third of the day." When did Lucas wake up?

- (A) at 1 o'clock (B) at 2 o'clock (C) at 3 o'clock (D) at 4 o'clock (E) at 5 o'clock

4. Clementine jumps on the tiles in the schoolyard according to the pattern drawn on the right: left foot – both feet – right foot – both feet – and then all over again as in the picture. She stops on the 48th tile. How many tiles has Clementine touched with her left foot?

- (A) 20 (B) 28 (C) 32 (D) 36 (E) 40



5. The number of dots on opposite faces of the die on the right add up to 7 as usual. The vertex labelled **A** is formed by the faces with 1, 2 and 3 dots and therefore has a vertex sum of $(1 + 2 + 3 =) 6$ dots. What is the maximum of the vertex sums of vertices **B**, **C** and **D**?

- (A) 10 (B) 11 (C) 12 (D) 13 (E) 14

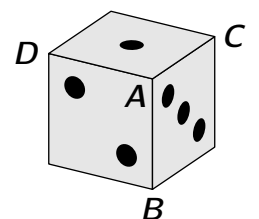

6. A famous band played a concert over the weekend. For the newspaper report, the editor rounds the number of visitors. She realizes that she gets the same number regardless of whether she rounds to tens or to hundreds. Which of the following numbers could be the number of visitors?

- (A) 3794 (B) 4912 (C) 5297 (D) 6586 (E) 7309

7. Tim wants to draw the figure shown in one go without lifting his pencil off the paper. The lengths of the lines are given in the figure. He can choose to start his drawing anywhere. What is the shortest distance he could draw to complete the figure?

- (A) 18 cm (B) 17 cm (C) 16 cm (D) 15 cm (E) 14 cm

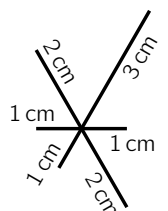

8. A three-digit palindromic number is a number of the form “ aba ” where the digits a and b can either be the same or different. For example, 272 and 555 are three-digit palindromic numbers. What is the sum of the digits of the largest three-digit palindromic number that is divisible by 2?

- (A) 25 (B) 23 (C) 21 (D) 18 (E) 16

9. The figure on the right shows a square with four circles of equal area each touching two sides of the square and two other circles. The area of the black region in the center is 1 cm^2 . What is the area of the entire grey region?

- (A) 2 cm^2 (B) 3 cm^2 (C) 4 cm^2 (D) 5 cm^2 (E) 6 cm^2

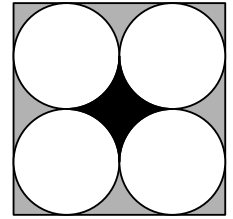

10. William has lots of cubes of the same size. He places one of them on the table. Then he adds 5 more cubes so that all the faces of the first cube are covered. Now he wants to add more cubes so that all the faces of the cubes already on the table are covered. How many additional cubes does William need at least?

- (A) 7 (B) 10 (C) 13 (D) 16 (E) 19

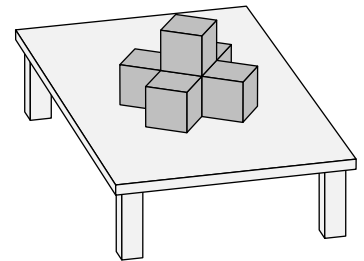

4 point problems

11. Five friends have entered their high jump results from the sports festival in a diagram. Adele says: “I think the one with the greatest jump height to body height ratio was the best.” Who was the best in Adele’s opinion?

- (A) Adele (B) Bea (C) Celine (D) Dilara (E) Erin

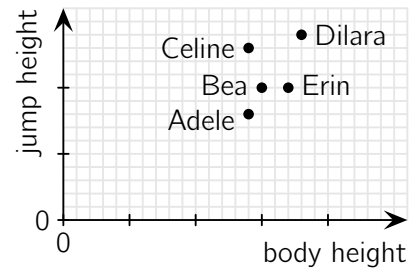

12. The 9th grade math club has planned a prime number school garden for the neighbouring elementary school. The rectangular garden is fenced in with 40 fence sections, each 1 m long, where the garden’s side lengths (in meters) are prime numbers. What is the garden’s largest possible area?

- (A) 77 m^2 (B) 82 m^2 (C) 85 m^2 (D) 91 m^2 (E) 97 m^2

13. In the picture on the right, the vertex S of the regular hexagon $NOPQRS$ is also the center of the square $KLMN$.

What is the size of the angle marked with the question mark?

- (A) 105° (B) 110° (C) 115° (D) 120° (E) 125°

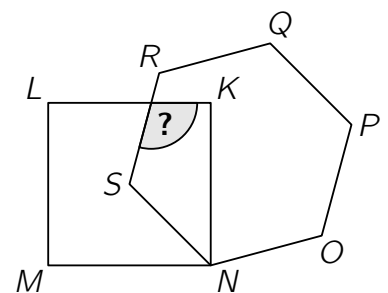

14. Neo places a black, a grey and a white square on top of each other in two different ways. In the left-hand picture, the visible black area is 8 times the area of the white square. What is the ratio of the visible black area to the area of the white square in the right-hand picture?

- (A) 9 : 2 (B) 4 : 1 (C) 8 : 3 (D) 5 : 2 (E) 7 : 1

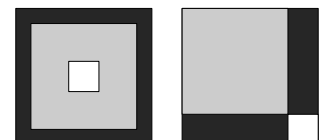

15. Jelena wants to place one of the letters A , B , C and D in every field of the 2×4 table shown on the right. Every letter must appear in each row as well as in every 2×2 square. How many possibilities are there for the completely filled 2×4 table?

- (A) 198 (B) 96 (C) 48 (D) 24 (E) 12

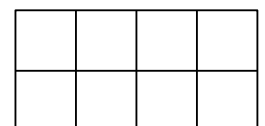

16. Four children each have a small chest with a key that only matches their own chest. For fun, they shuffle the keys and each child takes one at random. In how many ways can the keys be distributed among the four children so that exactly one child has the key that matches their own chest and the other three children do not?

- (A) 8 (B) 10 (C) 15 (D) 16 (E) 18

17. Christian has 12 tiles numbered 1 to 12. He places eight of them on the vertices of an octagon so that the sum of the numbers on every pair of tiles at adjacent vertices is divisible by 3. Which numbers are on the remaining 4 tiles?

- (A) 1, 5, 9, 12 (B) 3, 5, 7, 11 (C) 1, 2, 11, 12
 (D) 5, 6, 7, 8 (E) 3, 6, 9, 12

18. The equilateral triangle in the picture is divided into three parts by three line segments on the inside. These line segments are 2 cm, 3 cm and 6 cm long, respectively, and are each parallel to one of the sides of the triangle. What is the perimeter of the equilateral triangle?

- (A) 24 cm (B) 27 cm (C) 33 cm (D) 36 cm (E) 42 cm

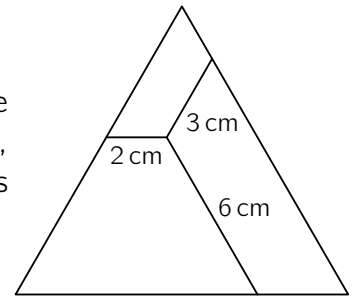

19. Katharina's granddaughter Nellie was born today. The ages of both Nellie's mother Anna and Katharina are even numbers. If you multiply the ages of Katharina, Anna and Nellie in exactly 2 years, you get 2024. How old is Katharina today?

- (A) 44 (B) 48 (C) 50 (D) 54 (E) 56

20. A large hall was uncovered during excavation work. Only some of the small floor tiles have survived, but it has been possible to reconstruct that the floor was tiled as shown in the section on the right. The archaeologists estimate that there were originally around 2000 hexagonal tiles. How many triangular tiles were there originally?

- (A) around 3000 (B) around 4000 (C) around 5000 (D) around 6000 (E) around 8000

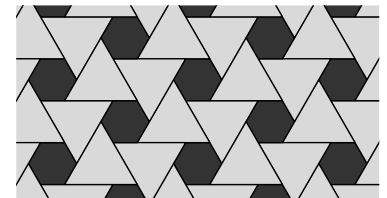

5 point problems

21. The guardian of the realm of Primalia always alternates between speaking the truth all day and lying all day. On one day she made exactly four of the following five statements. Which statement is not from that day?

- (A) 2024 ist not a prime number.
 (B) I am telling the truth today and I will tell the truth tomorrow.
 (C) I lied yesterday and I will lie tomorrow.
 (D) Tomorrow is Monday.
 (E) Yesterday was Thursday.

22. A natural number should be written in each of the circles in the picture on the right. The number inside each square indicates the product of the numbers at its four vertices. What will be the product of the numbers in the 8 grey circles?

- (A) 20 (B) 40 (C) 80 (D) 120 (E) 360

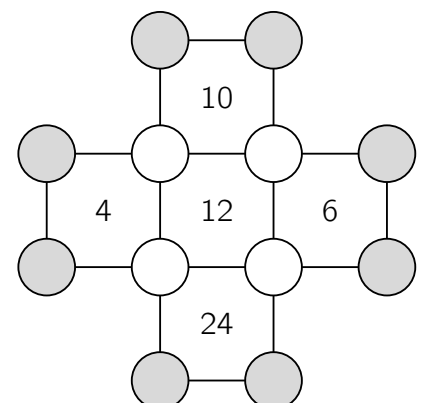

23. Otis wants to make the solid shown, a cube with two pyramids attached. To do this, he draws a net of squares and equilateral triangles. The side length of the squares and triangles is 1 cm each. What is the distance between the tips of the pyramids *A* and *B* in the finished solid?

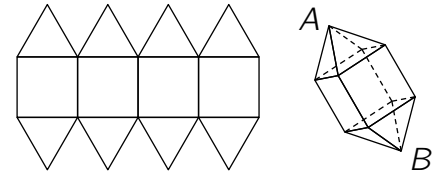

- (A) $\sqrt{5}$ cm (B) $(1 + \sqrt{3})$ cm (C) $2\sqrt{2}$ cm (D) $\frac{5}{2}$ cm (E) $(1 + \sqrt{2})$ cm
24. Four friends are having pizza. When they have finished, there are still a few slices left. There are as many slices left on the 1st plate as there are plates with exactly 1 slice. There are as many slices left on the 2nd plate as there are plates with exactly 2 slices. There are as many slices left on the 3rd plate as there are plates with exactly 3 slices. There are as many slices left on the 4th plate as there are empty plates. How many slices are left in total?
- (A) 2 (B) 3 (C) 4 (D) 5 (E) 6
25. Leo has built a large $3 \times 3 \times 3$ cube from 27 small cubes of the same size. The small cubes are black, grey or white. The surface of the large cube is one third black, one third grey and one third white. Leo has used the largest possible number of black cubes and the smallest possible number of white cubes. How many grey cubes did Leo use?
- (A) 5 (B) 6 (C) 7 (D) 8 (E) 10
26. The sum of the digits of the natural number N is twice the sum of the digits of its successor $N + 1$. What is the smallest possible sum of the digits of N ?
- (A) 10 (B) 12 (C) 14 (D) 16 (E) 18
27. On the right you can see the prime factorisation of $n! = 1 \times 2 \times \dots \times n$ for a given natural number n . Some prime numbers and some exponents are hidden. Which exponent belongs to the prime factor 17?
- $2 \times 3 \times 5 \times 7 \times 11 \times 13^4 \times 17 \times \dots \times 43 \times 47$
- (A) 1 (B) 2 (C) 3 (D) 4 (E) 5
28. Nina has divided a circle with 20 points into 20 arcs of equal length. She draws all the chords that connect two of these points. How many of these chords are longer than the radius but shorter than the diameter of the circle?
- (A) 90 (B) 100 (C) 120 (D) 140 (E) 160
-
29. Mert has rolled a normal 6-sided die 18 times. He has rolled the number 1 more often than any of the other numbers 2, 3, 4, 5 and 6. The sum of all the numbers rolled is the largest possible sum under these conditions. What is this sum?
- (A) 71 (B) 69 (C) 68 (D) 63 (E) 62
30. Olya walked in the park. She walked half of the total time at a speed of 2 km/h. She walked half of the total distance at a speed of 3 km/h. She walked the rest of the time at a speed of 4 km/h. What fraction of the total time did she walk at a speed of 4 km/h?
- (A) $\frac{1}{7}$ (B) $\frac{1}{12}$ (C) $\frac{1}{4}$ (D) $\frac{1}{5}$ (E) $\frac{1}{14}$